

efergy®

CE RoHS



N16354



elite

μ

μ

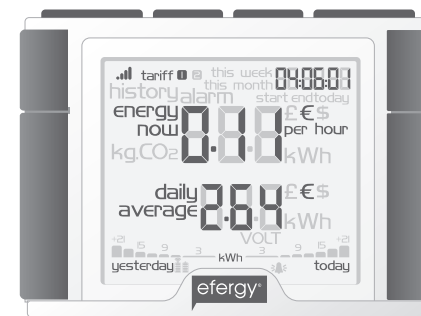

efergy®



.....	1
.....	2
.....	3
..... ()	4
.....	6
..... ()	7
/ &	8
.....	9
.....	11
.....	13
.....	14
.....	15
.....	16

Model Name/Number: efergy elite 2.0

: 433.52MHz

μ : 6s, 12s. o 18s.

μ : 40m-70m

(): 110V-400V

μ μ : 50mA-95A

: >90%

μ r μ 18:00 06:00

CO2 : 0.50 kg, CO2 / kWh



μ
:
μ μ μ
μ elite
μ
μ μ
μ
μ elite,
μ μ
μ μ

Email: info@dtsenergy.gr & nfo@efergy.com

: service@dtsenergy.gr & askgeorge@efergy.com

μ μ μ 48

: (+30) 2310 88 66 82

Efergy Customer Service. T +44 (0) 8450 177 769





:
 elite
 (),
 40
 433 MHz
 LINK.
 LINK.
 LINK.



;
 ;
 ();
 MODE DATE 2
 40
 433 MHz
 3
 LINK.
 LINK.
 LINK.



μ , μ , μ

μ HISTORY,

μ μ

μ BWD FWD μ

μ

μ

μ

μ

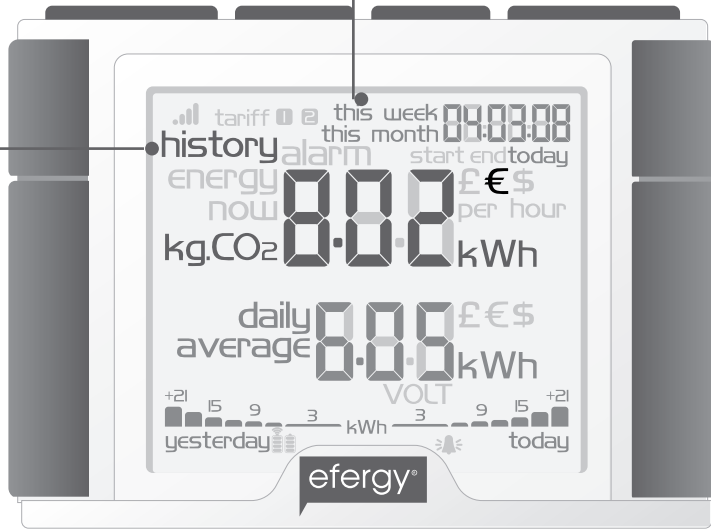

HISTORY

μ

μ

μ

μ

MODE μ

μ

KWh

μ

CO2



efergy elite μ

μ :

1 x

1 x μ

1 x

()

()

μ

μ

μ

μ

μ

-1 x

-1 x

μ

()

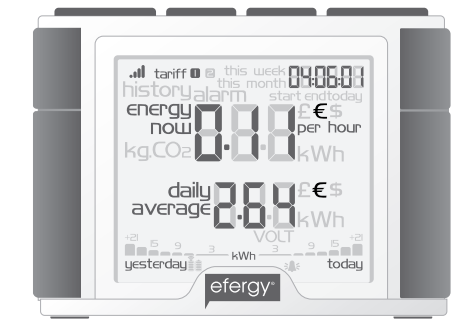
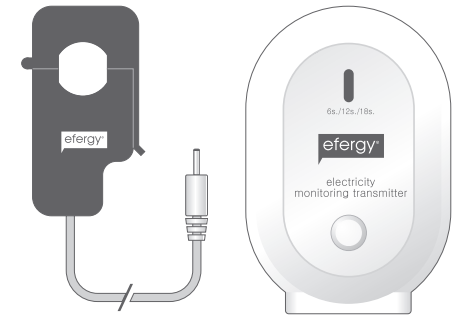

μ : μ μ μ
 07:00, μ μ 23:00
 MODE
 . . 0,05c/kWh 0.16c/kWh

μ 3. μ μ μ μ 0,15c/kWh
 μ μ BWD FWD μ .
 MODE μ μ

μ 4. μ μ μ μ 0,05c/kWh
 μ μ BWD FWD μ .
 MODE μ μ

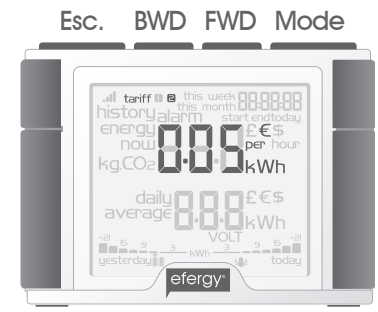
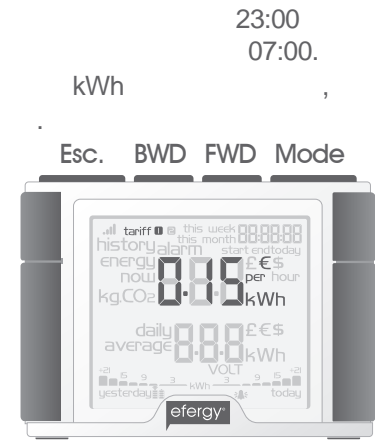

(2)
 (,) . μ
 μ μ μ μ 3- μ
 μ μ μ μ 12mm, μ
 μ μ μ μ

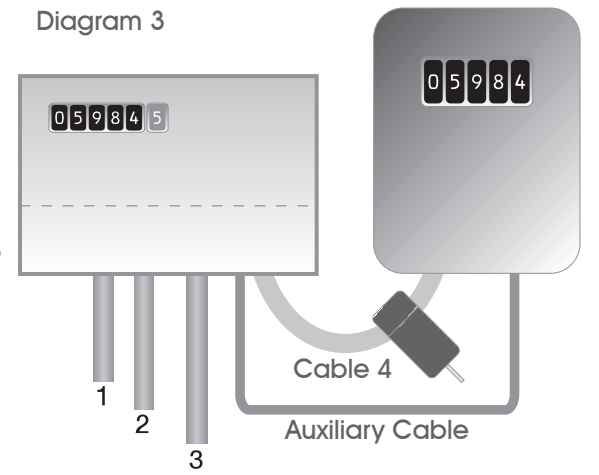

1.

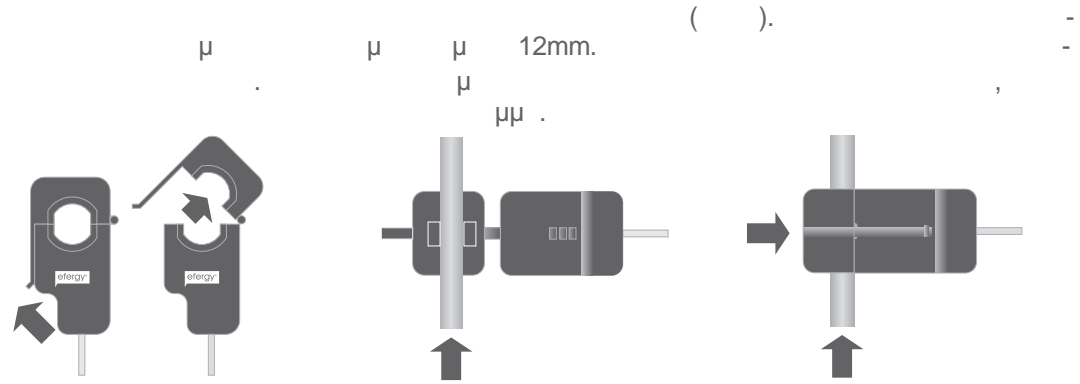

1.

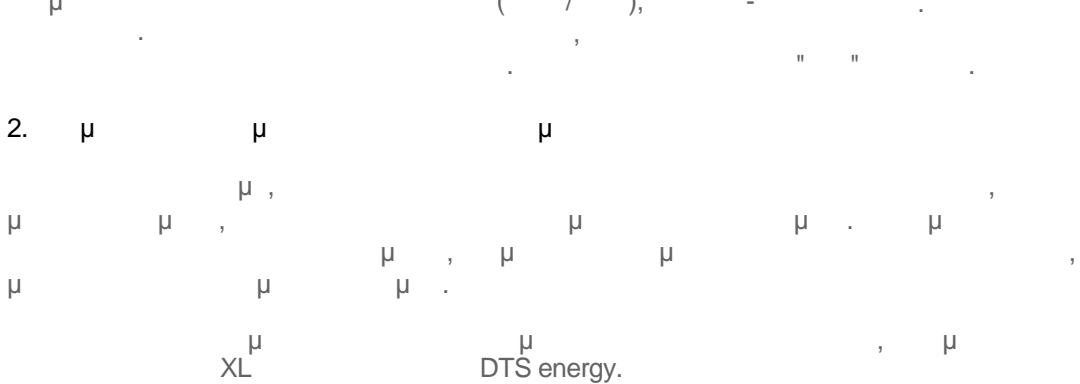

6



2.

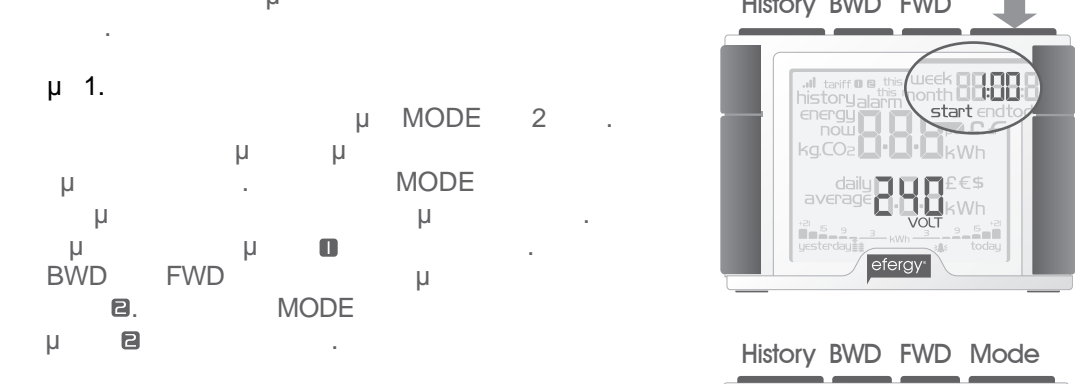

2.

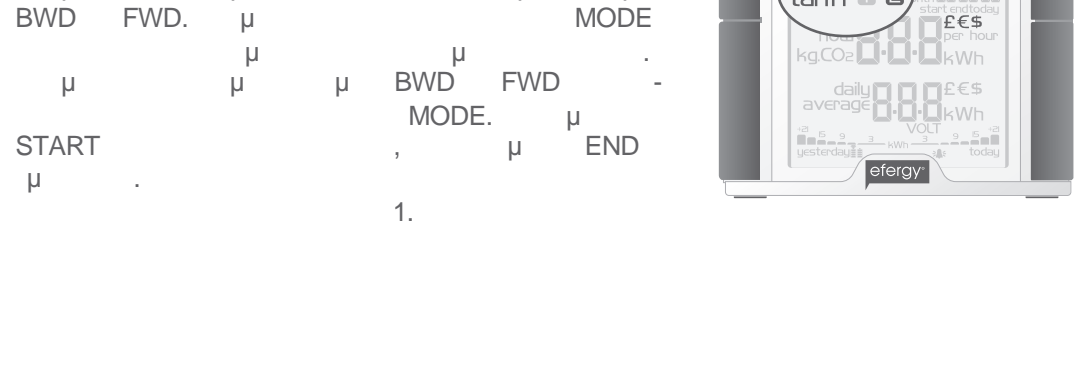

6

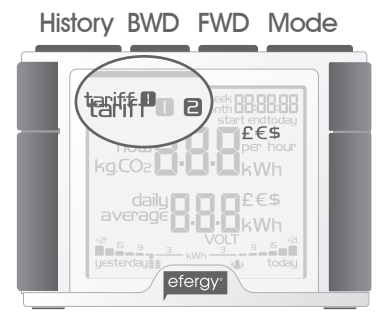
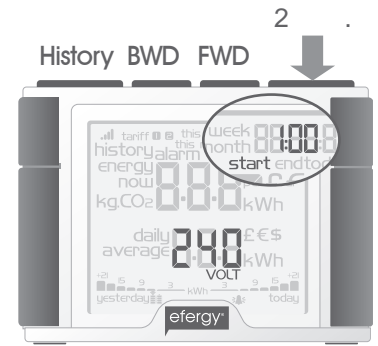

11

